

# Silicon Controlled Rectifier Series 080

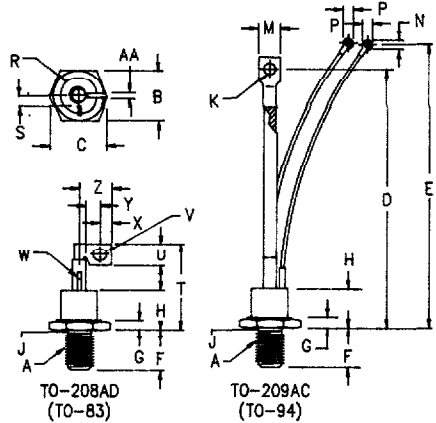

Note 1: 1/2-20 UNF-3A  
 Note 2: Full thread within 2 1/2 threads  
 Note 3: To specify package designation other than standard lead enter appropriate letter in place of "A".  
 "B" = Insulated lead  
 "D" = Flag Terminal  
 "C" = Top Stud (consult factory)

Dim.	Inches		Millimeter		Notes
	Minimum	Maximum	Minimum	Maximum	
A	---	---	---	---	1
B	1.050	1.060	26.67	26.92	
C	---	1.161	---	29.49	
D	5.850	6.144	149.10	156.06	
E	6.850	7.375	173.99	187.33	
F	.797	.827	20.24	21.01	
G	.276	.286	.701	7.26	
H	---	.948	---	24.08	
J	.425	.499	10.80	12.67	2
K	.260	.280	6.60	7.11	Dia.
M	.500	.600	12.70	15.24	
N	.140	.150	3.56	3.81	
P	---	.295	---	7.49	
R	---	.900	---	22.86	Dia.
S	.225	.275	6.48	6.99	
T	---	1.750	---	44.45	
U	.370	.380	9.40	9.65	
V	.213	.223	5.41	5.66	Dia.
W	.065	.075	1.65	1.91	Dia.
X	.215	.225	5.46	5.72	
Y	.290	.315	7.37	8.00	
Z	.514	.530	13.06	13.46	
AA	.089	.099	2.26	2.51	

Microsemi Catalog Number	Forward & Reverse Repetitive Blocking	Reverse Transient Blocking
Standard Lead	Flag Lead	
08002GOA	08002GOD	200
08003GOA	08003GOD	300
08004GOA	08004GOD	400
08005GOA	08005GOD	500
08006GOA	08006GOD	600

To specify dv/dt other than 200V/usec., contact factory.

- High dv/dt-200 V/usec.
- 1800 Amperes surge current
- Low forward on-state voltage
- Package conforming to either TO-209AC or TO-208AD outline
- Economical for general purpose phase control applications



### Electrical Characteristics

Max. RMS on-state current	$I_T(\text{RMS})$ 125 Amps	$T_C = 87^\circ\text{C}$
Max. average on-state cur.	$I_T(\text{AV})$ 80 Amps	$T_C = 87^\circ\text{C}$
Max. peak on-state voltage	$V_{TM}$ 1.4 Volts	$I_{TM} = 220 \text{ A(peak)}$
Max. holding current	$I_H$ 200 mA	
Max. peak one cycle surge current	$I_{TSM}$ 1800 A	$T_C = 87^\circ\text{C}, 60 \text{ Hz}$
Max. I <sup>2</sup> t capability for fusing	$I^2t$ 13,500A <sup>2</sup> S	$t = 8.3 \text{ ms}$

### Thermal and Mechanical Characteristics

Operating junction temp range	$T_J$	-40°C to 125°C
Storage temperature range	$T_{STG}$	-40°C to 150°C
Maximum thermal resistance	$R_{\theta JC}$	0.40°C/W Junction to case
Typical thermal resistance	$R_{\theta CS}$	0.40°C/W Case to sink
Max mounting torque		130 inch pounds maximum
Weight		080-GOA Approx. 3.6 ounces (102.0 grams) typical 080-GOD Approx. 3.24 ounces (91.8 grams) typical

**Microsemi Corp.**  
⊗ **Colorado**

PH: 303-469-2161  
 FAX: 303-466-3775

# 080

Switching			
Critical rate of rise of on-state current (note 1)	$di/dt$	100A/usec.	$T_J = 125^\circ\text{C}$
Typical delay time (note 1)	$t_d$	3.0 usec.	
Typical circuit commutated turn-off time (note 2)	$t_q$	100 usec.	$T_J = 125^\circ\text{C}$
Note 1: $I_{TM} = 50\text{A}$ , $V_D = V_{DRM}$ , $V_{GT} = 12\text{V}$ open circuit, 20 ohm-0.1 usec. rise time Note 2: $I_{TM} = 50\text{A}$ , $di/dt = 5\text{A/usec.}$ , $V_K$ during turn-off interval = 50V min., reapplied $dv/dt = 20\text{V/usec.}$ , linear to rated $V_{DRM}$ , $V_{GT} = 0\text{V}$			

Triggering			
Max. gate voltage to trigger	$V_{GT}$	3.0V	$T_J = 25^\circ\text{C}$
Typical gate voltage to trigger	$V_{GT}$	1.0V	$T_J = 25^\circ\text{C}$
Max. nontriggering gate voltage	$V_{GD}$	0.25V	$T_J = 125^\circ\text{C}$
Max. gate current to trigger	$I_{GT}$	100mA	$T_J = 25^\circ\text{C}$
Typical gate current to trigger	$I_{GT}$	48mA	$T_J = 25^\circ\text{C}$
Max. peak gate power	$P_{GM}$	15W	
Average gate power	$P_{G(AV)}$	3.0W	$t_p = 10 \text{ usec.}$
Max. peak gate current	$I_{GM}$	4.0A	
Max. peak gate voltage (forward)	$V_{GM}$	10V	
Max. peak gate voltage (reverse)	$V_{GM}$	5.0V	

Blocking			
Max. leakage current	$I_{DRM}$	10mA	$T_J = 125^\circ\text{C}$ & $V_{DRM}$
Max. reverse leakage	$I_{RRM}$	10mA	$T_J = -125^\circ\text{C}$ & $V_{RRM}$
Critical rate of rise of off-state voltage	$dv/dt$	200V/usec.	$T_J = 125^\circ\text{C}$

Figure 1  
Typical Forward On-State Characteristics

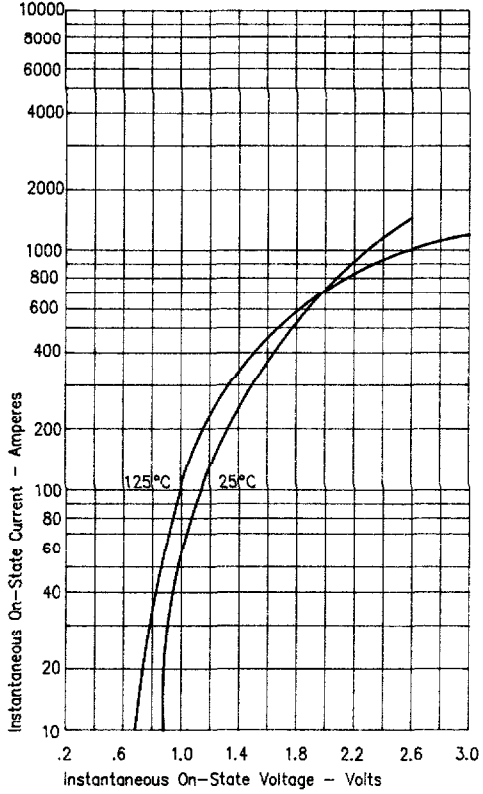

Figure 3  
Maximum Power Dissipation

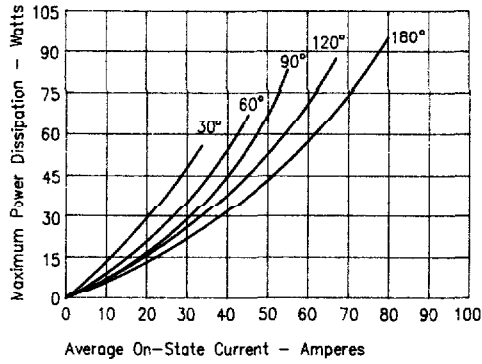

Figure 4  
Transient Thermal Impedance

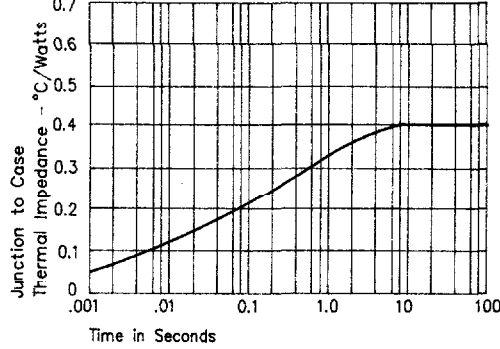

Figure 2  
Forward Current Derating

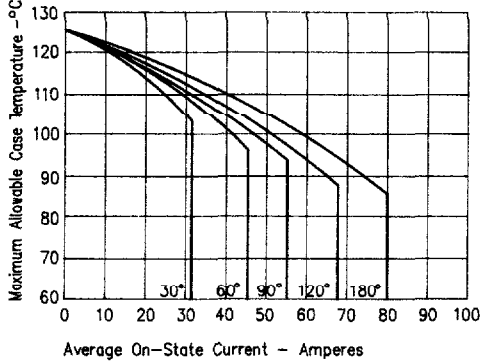

Figure 5  
Maximum Nonrepetitive Surge Current

